

submittal

Job _____
 Location _____
 Submitted to _____
 Submittal Prepared by _____
 Approve Date _____
 Date _____

Fire Damper Series 65 Type B

UL Classified - 1½ Hour Rating, Static
 For use in installations rated less than 3 hours

Thinline Profile (2") 22 Ga
 1 piece rollformed frame

Type B Damper
 Blades out of air-stream

Available for vertical and horizontal installations

Standard fusible link - 165° F (optional 212° F)

Available in stainless steel

Available in single-section sizes from

Vertical - 4" x 3" to 48" x 41"

Horizontal - 4" x 3" to 36" x 30"

Optional 22 Ga Sleeve available:

8", 12", 17", 20", or 24" lengths (12" is standard)

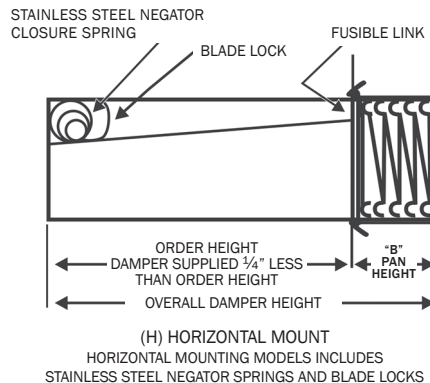
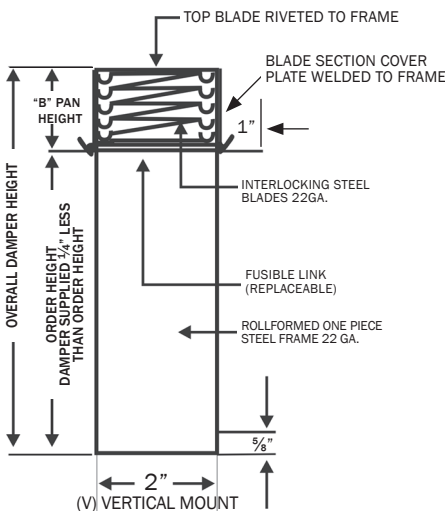
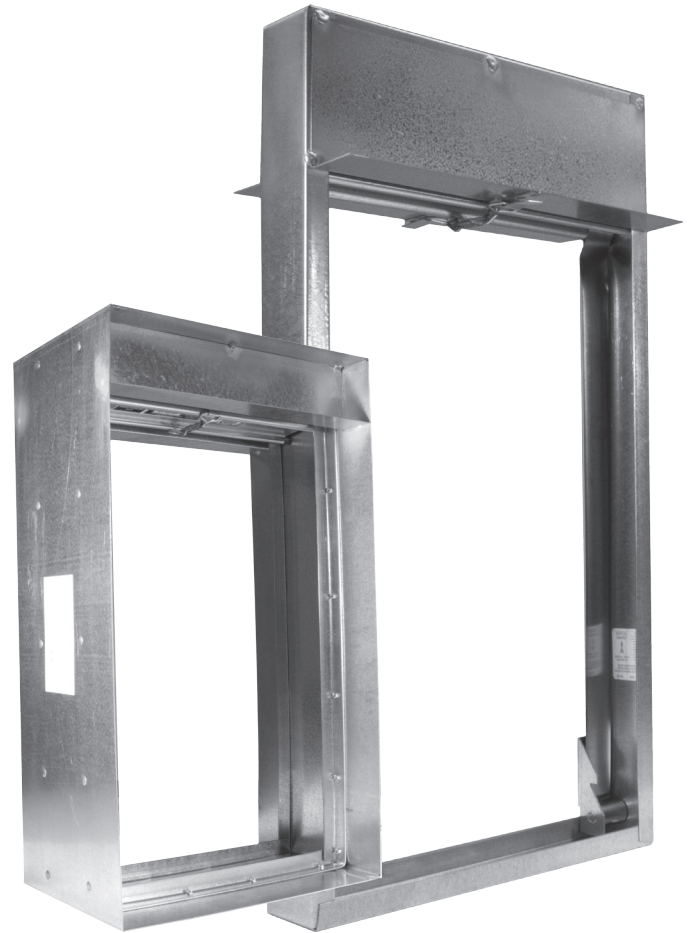

This product meets the requirements
 for fire dampers established by:

UL Standards 555
NFPA Standard 90A
ICC Building Codes

Qty.	Mount	Damper Size		Fusible Link Temp (165°F) std.	Factory Sleeve Length
	(V) vertical (H) horizontal	W	H		

Part Number Format

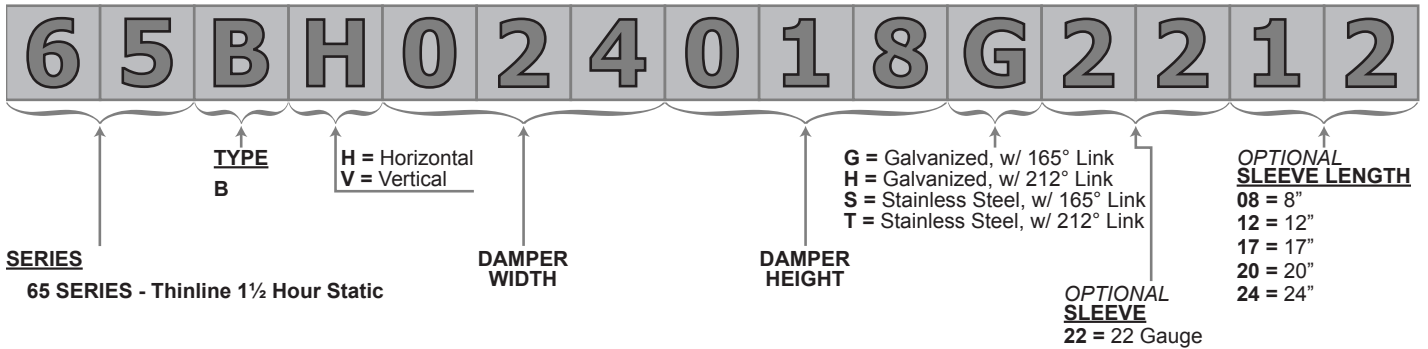

Submittal



AireTechnologies, Inc.
a DMI company

AireTechnologies, Inc.
1502 Industrial Drive
E. Monongahela, PA 15063

phone: 866.421.AIRE
fax 724.310.1262

www.airetechnologies.com