

# submittal

Job \_\_\_\_\_  
 Location \_\_\_\_\_  
 Submitted to \_\_\_\_\_  
 Submittal Prepared by \_\_\_\_\_  
 Approve Date \_\_\_\_\_  
 Date \_\_\_\_\_

## Fire Damper Series 75 Type A

UL Classified - 1½ Hour Rating, Static  
 For use in installations rated less than 3 hours

Standard Profile (4¼") 22 Ga

Type A Damper  
 Blades in air-stream

Available for vertical and horizontal installations

Standard fusible link - 165° F (optional 212° F)

Available in stainless steel

Vertical dampers are available in single-section sizes  
 from 4" x 4" to 60" x 60"  
 multi-section sizes to 120" x 120"

Horizontal dampers are available in single-section sizes  
 from 4" x 4" to 40" x 60"  
 multi-section sizes to 120" x 120"

Optional 22 Ga Sleeve available:  
 8", 12", 17", 20", or 24" lengths (12" is standard)

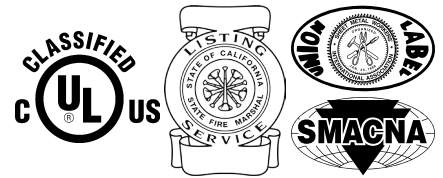
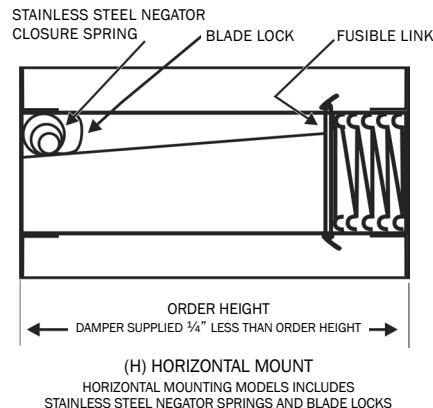
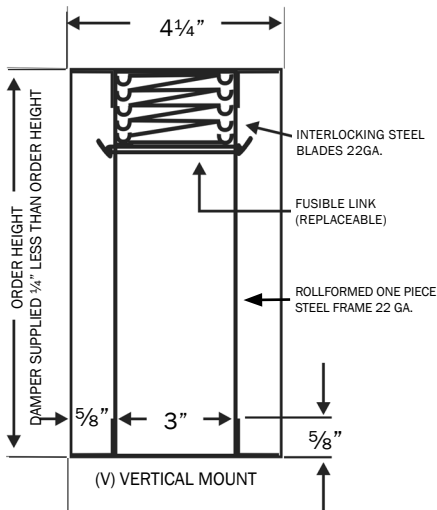
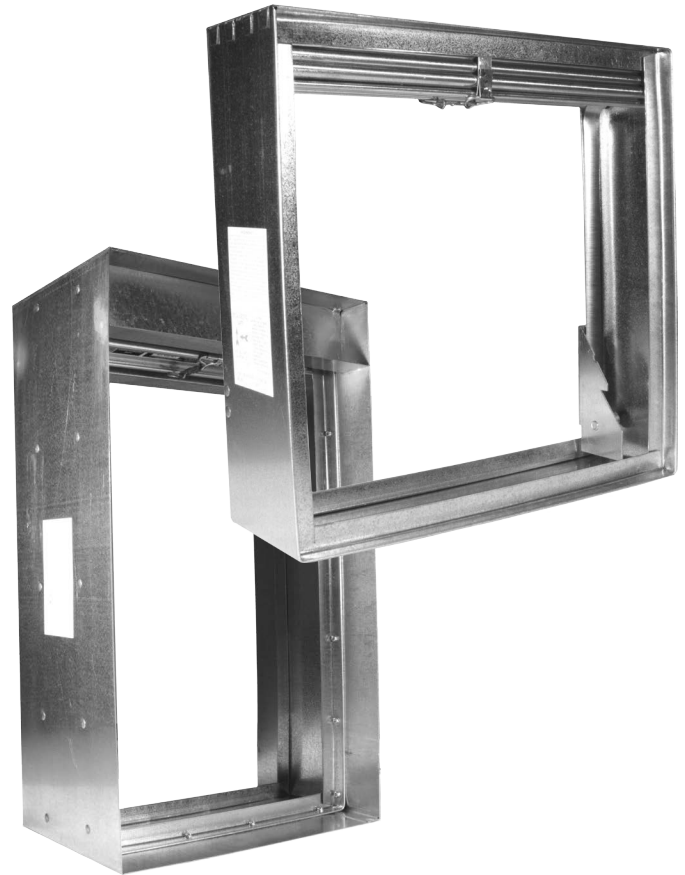

This product meets the requirements  
 for fire dampers established by:

**UL Standards 555**  
**NFPA Standard 90A**  
**ICC Building Codes**

Qty.	Mount	Damper Size		Fusible Link Temp (165°F) std.	Factory Sleeve Length
	(V) vertical (H) horizontal	W	H		

## Part Number Format

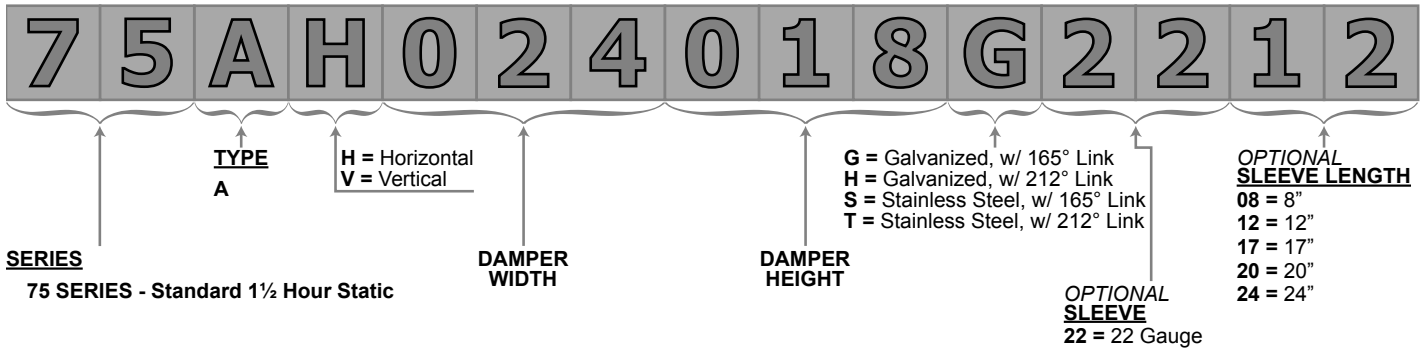

# Submittal



**Aire Technologies, Inc.**  
a DMI company

Aire Technologies, Inc.  
1502 Industrial Drive  
E. Monongahela, PA 15063

phone: 866.421.AIRE  
fax 724.310.1262

www.airetechnologies.com